

S-Transform based Neural Network for Power Quality Disturbances Recognition and Classification

Yogita P. Bochare
M.E (EPS) student
Department of Electrical Engineering,
MGI-COET, Shegaon.
yogitabochar35@gmail.com

P.W. Choudhary
Assistant Professor
Department of Electrical Engineering
MGI-COET, Shegaon
c.pratik55@gmail.com

Dr. M. A. Beg
Head of Department
Department of Electrical Engineering,
MGI-COET, Shegaon
ansarbeg@gmail.com

Abstract— Power Quality has become a main problem in the electric power system. The wide use of non-linear loads and other electronic equipment's can causes power disturbances which then lead to poor power quality. Poor power quality is caused by power line disturbances, instability, and short lifetime resulting in failure of End user equipment. To improve the power quality, it is essential to detect, localize and classify power quality disturbances accurately. In this paper, IEEE14 bus system is simulated in Power System Computer Aided Design (PSCAD) software. This paper mainly detects and classify Power quality disturbances such as Voltage sag and Voltage swell. S-transform is used to extract distinguishing features and Artificial Neural Network (ANN) is used as a classifier. Power quality disturbances are localized by S-transform in time and frequency domain.

Keywords- Power quality disturbance, IEEE14 bus system, S-transform, Artificial Neural Network (ANN).

I. INTRODUCTION

A. Introduction

Power quality has become an important topic of discussion and research these days. Poor quality of electric power is caused by the power line disturbances resulting in sag, swell, interruption, sag with harmonic, flicker, harmonic and notches, etc. Power quality is an important issue for utilities and end users. The increasing number of disturbing loads in industrial and public sectors causes power quality disturbances. Electrical power engineers have always been concerned about power quality. They see power quality as anything that affect the voltage, current, and frequency of the power being supplied to the end users i.e. the ultimate user or consumer of electricity.

The electronic (non-linear) load causes many Power quality problems resulting in the failure of End user equipment. For improvement of Power Quality, the disturbances should be detected, localized and mitigated.

B. Literature Review

[1] Nantian Huang, et al. analysed by power quality of S-transform and 18 features are extracted to identify different types of disturbances. This feature selection not only reduces the computational time and spatial costs of the PNN but also improves the classification efficiency of the proposed classifier. As a result of the advantages of the probabilistic neural network the new classifier is efficient and accurate. In this paper it is observed that results of a comparison test show that the PNN-based classifier was more accurate than BPNN and RBPNN approaches and that it could be used in high noise applications.

[2] A.Rodriguez, et al. presents a rule based approach for the classification of Power quality disturbances. The disturbed

signal is first characterized using the multiresolution S-transform, which act as a feature extraction tool. In this paper the tested data set contains power quality signals obtained using mathematical models, power quality events obtained from power networks simulation using PSCAD\EMTDC and measured signal at electrical installation.

[3] Suriya Kaewarsa, et al. presents a novel approach for the recognition of power quality disturbances using multiwavelet transform and neural networks. In this various transient events are tested, such as voltage sag, voltage swell, interruption, notching, impulsive transient and harmonic distortion show that the classifier can detect and classify different Power quality signal type's efficiency.

[4] C. N. bhende, et al. presents an s-transform based modular neural network (NN) classifier for recognition of power quality disturbances. By introducing the modular neural network concept for disturbance classification disturbance classification the task complexity is reduced and learning capability is increased.

[5] S. Mishra, et al. presents an s-transform based neural network classifier to detect and classify the power quality disturbance. In this paper, S-transform is used to detect the disturbance in a power signal and classified using PNN which shows that s-transform has better detection capability and Probabilistic Neural Network (PNN) gives best classification results.

C. Objective of Work

The main objective of this paper is the detection and classification of Power Quality disturbances

- (i) Voltage sag
- (ii) Voltage swell

II. S- TRANSFORM

S-transform (ST) is the extension of wavelet transform and short time Fourier transform which overcomes the limitation of wavelet transform and short time Fourier transform. In 1996 S-transform was first proposed by R. G. Stock well. Major time frequency method of S-transform develops on the basis of STFT and CWT as a time frequency analysis technique, enjoying many advantages, such as linearity, loss less reversibility, multiresolution, good time frequency resolution etc. an important property of S-transform is that it combines a frequency dependent resolution of the time frequency space and absolutely referenced local phase information [6]. There are several ways to represent the idea of the s-transform. S-transform is desired as the phase correction of the continuous wavelet transform with window being the Gaussian function. S-transform has the ability to detect the fault correctly in the presence of noise due to which it is very popular in detecting power system faults and Power quality disturbances. S-transform is based on moving scalable modulating Gaussian window.

The generalized S-transform is given by:

The S-transform of a basic continuous signal $h(t)$ is defined by equation (1)

$$s(\tau, f) = \int_{-\infty}^{\infty} h(t)g(\tau - t, f)e^{-j2\pi ft} dt \quad (1)$$

Where f is the frequency τ and t are both time

III. CASE STUDY

Fig. 1 shows single line diagram of IEEE 14 bus system. In this 3 phase transmission of rating 230 kV and length of 1 km is considered and the network has 14 buses which are interconnected 20 transmission lines. Two generators are connected on bus 1 and 2 respectively and three of which are synchronous compensators used only for reactive power support. System frequency is 60Hz and base MVA is 285.81MVA.

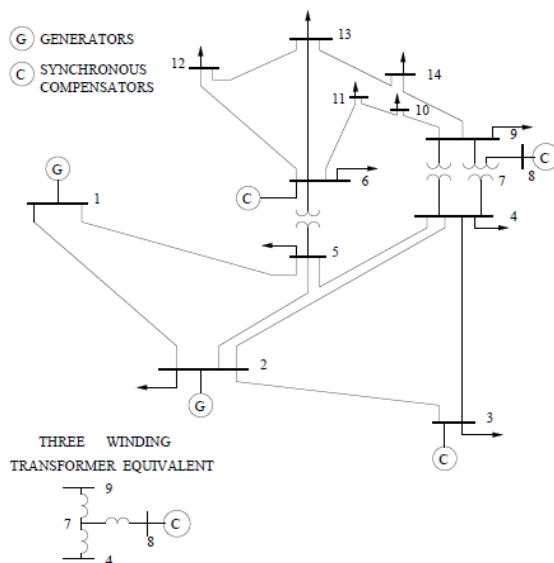

Fig. 1 Single line diagram of IEEE 14-Bus system

Simulation of circuit in PSCAD-

Normal system:

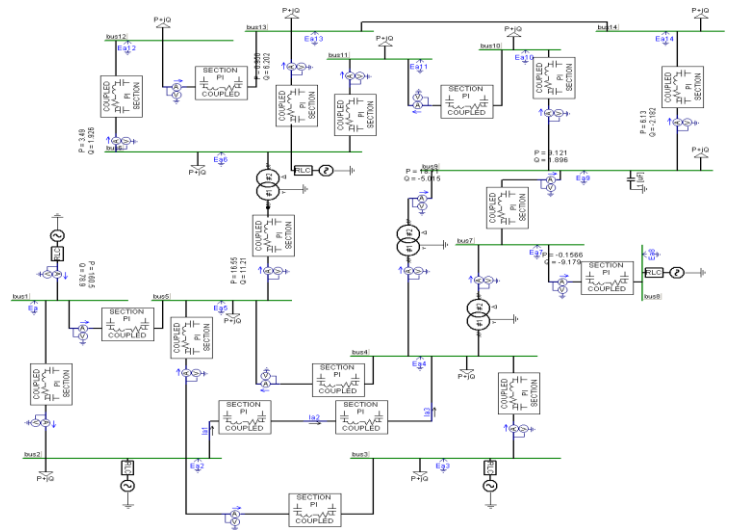

Fig 2. PSCAD simulation of IEEE 14-Bus system

Fig 2 Shows simulation of IEEE 14 bus Test system in PSCAD software during Normal condition in which π section transmission lines of 1km are used for connecting various buses. Sources are connected to bus No. 3,6 and 7. Transformers are connected between bus 4 and 7, bus 4and 9, bus 5 and 6. Multimeters are connected between each line for measuring voltage, current, active and reactive power flowing through the line. Also voltmeters are connected on each bus for measuring phase voltage on each bus.

In IEEE 14 bus system Power Quality events such as Voltage Sag, Voltage Swell are created at Bus No. 3, 5, and 7 and voltage signals for these events are captured for further analysis. Fundamental system frequency is 60Hz and base voltage is 230Kv. Disturbances are created on the system for 20 cycles with sampling frequency of 1kHz.

Duration of run = 0.033 second = 2 cycles

IV. PROPOSED METHODOLOGY

In (PSCAD) simulation, first the IEEE 14 bus system is simulated. IEEE 14 bus distribution system is taken under study for detection and classification of power quality events. S-Transform and Artificial Neural Network (ANN) is used to detect and classify power quality disturbances. Power quality disturbances are identified by S-Transform in time and frequency domain. Also, S-Transform is used to extract the disturbance features in Power signal. The voltage signal are taken at a different buses and sampling them at 1 kHz .The excel sheets are formed in PSCAD and exported it to MATLAB program for S-transform analysis. Energy is calculated from detailed coefficients of S-Transform which is given as input to Artificial Neural Network (ANN) after calculating features to classify power quality disturbances such as voltage sag, voltage swell.

V. ARTIFICIAL NEURAL NETWORK (ANN)

An artificial neural network is a computational model based on the structure and the function of a biological neural network. Artificial neural network are considered non-linear statistical data modeling tools where the complex relationship between the input and output are modeled or pattern are found.

(a) Architecture of ANN information-

The network architecture has an input layer, hidden layer (there can be more than one) and the output layer, it is also called MLP (Multilayer perceptron) because of the multiple layers.

(b) The hidden layer can be seen as a “distillation layer” that distills some of the important patterns from the inputs and passes it onto the next layer to see. It makes the network faster and efficient by identifying only the important information from the inputs leaving out the redundant information.

(c) ANN has so many advantages like it requiring a less formal statistical training and ability to implicitly detect complex non-linear relationship between dependent and independent variables. Also it has the ability to detect all possible interaction between predictor variables and the availability of multiple training algorithms.

Fig. 3 shows an Artificial Neural Network

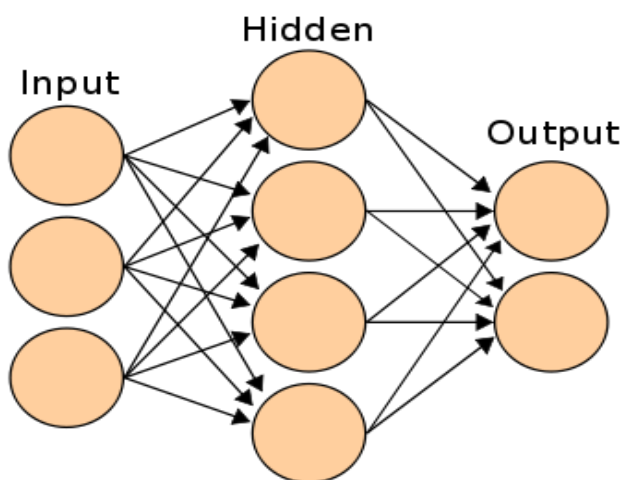

Fig. 3 Artificial Neural Network

VI. FLOWCHART

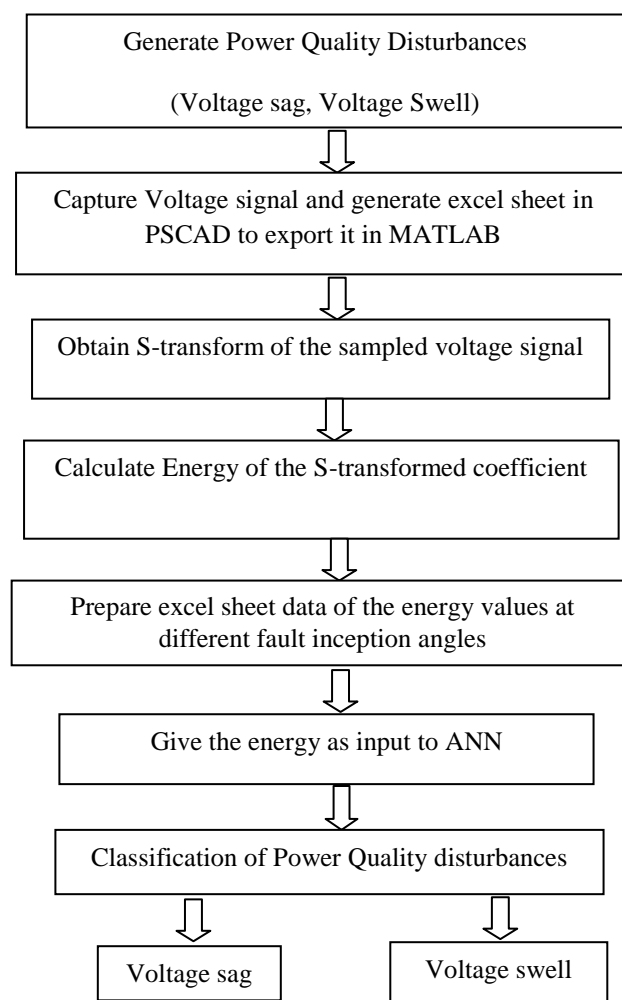

Fig. 4 Proposed Algorithm for Power Quality disturbances

VII.PSCAD SIMULATION WAVEFORMS

The system under study is simulated in PSCAD software and Power Quality events such as Voltage sag, Voltage Swell are created at $0^{\circ}, 45^{\circ}, 90^{\circ}, 135^{\circ}, 180^{\circ}, 225^{\circ}, 270^{\circ}, 315^{\circ}, 360^{\circ}$ voltage instant in the system. Following are the Voltage waveform for Voltage sag, Voltage swell on Bus 3, 5, and 7 at $0^{\circ}, 45^{\circ}, 90^{\circ}$.

PSCAD Simulation waveform at 0° instant:

(1)Voltage Sag:

Voltage sag is created at Bus No.3, 5, and 7 using L-G fault for duration of 0.3 sec. The Voltage waveform for Voltage sag on Bus 3, 5, and 7 at fault inception angle 0° instant are as shown in figure below.

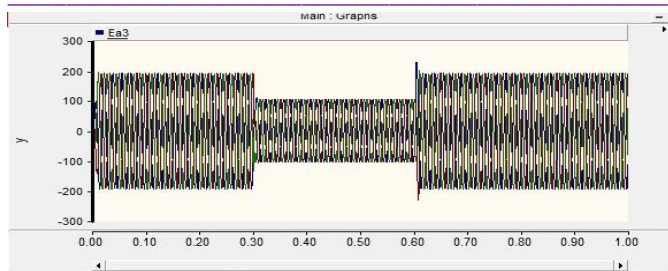

Fig. 5 Voltage sag on Bus 3 at fault inception angle 0° instant

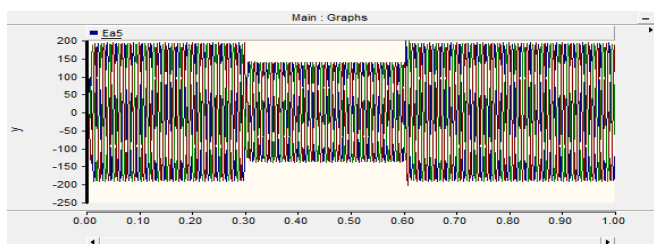

Fig. 6 Voltage sag on Bus 5 at fault inception angle 0° instant

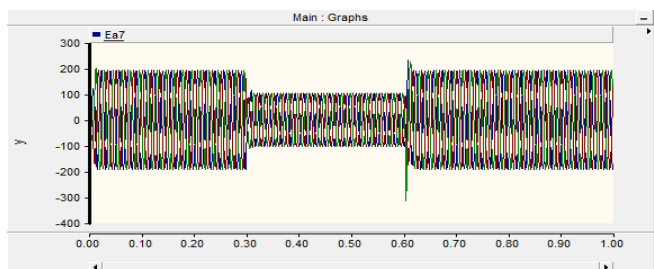

Fig. 7 Voltage sag on Bus 7 at fault inception angle 0° instant

(2) Voltage Swells:

Voltage swell is created at Bus No.3, 5, and 7 by switching off the heavy load for the duration of 0.3 sec. The Voltage waveform for Voltage swell on Bus 3, 5, and 7 at fault inception angle 0° instant are as shown in figure below.

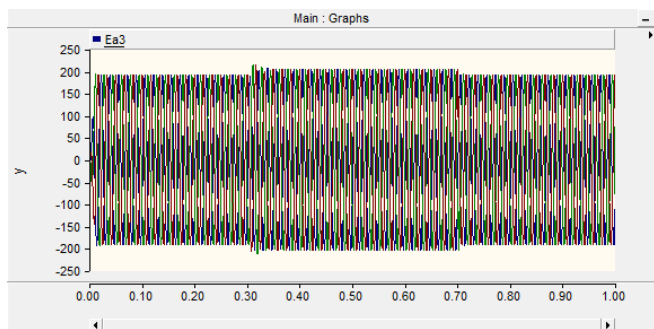

Fig. 8 Voltage swell on Bus 3 at fault inception angle 0° instant

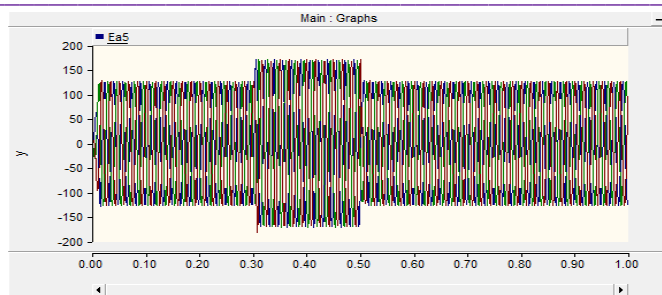

Fig. 9 Voltage swell on Bus 5 at fault inception angle 0° instant

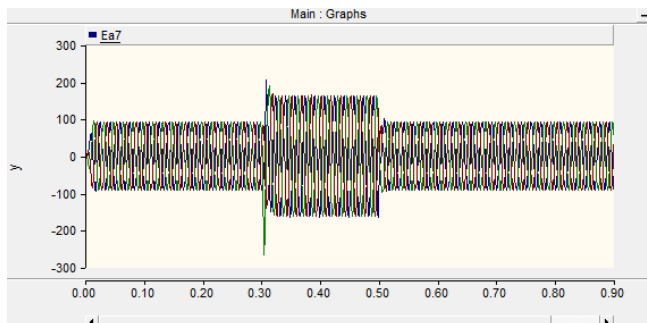

Fig. 10 Voltage swell on Bus 7 at fault inception angle 0° instant

S-Transform Energy values Results:

S-Matrix is obtained at the output of S transform program. It is complex matrix contains real and imaginary values. Normalized frequency is used to calculate energy of the signal. Energy of the voltage signals are calculated for different faults at different fault inception angles 0° , 45° and 90° .

1 Energy values in p.u. of Voltage signals for 0° fault inception angle:

TABLE I.

Bus NO.	Event name	Phase		
		a	b	c
Bus 3	Sag 3	4.07	36.68	55.97
	Swell 3	4.069	3.90	20.36
Bus 5	Sag 5	4.08	22.46	31.15
	Swell 5	4.07	21.43	20.36
Bus 7	Sag 7	4.08	32.10	32.88
	Swell 7	4.06	30.18	32.08

2 Energy values in p.u. of Voltage signals for 45° fault inception angle:

TABLE II.

Bus No.	Event name	Phase		
		a	b	c
Bus 3	Sag 3	4.0952	22.2581	31.1350
	Swell 3	4.0652	3.3484	60.2063
Bus 5	Sag 5	4.0819	36.3625	24.3875
	Swell 5	4.0673	3.7116	22.2078
Bus 7	Sag 7	4.0819	36.36	24.38
	Swell 7	4.0716	3.8783	32.8431

3 Energy values in p.u. of Voltage signals for 90° fault inception angle.

TABLE III.

Bus No.	Event name	Phase		
		a	b	c
Bus 3	Sag 3	4.0845	26.0968	31.75
	Swell 3	4.0653	3.3574	49.2040
Bus 5	Sag 5	4.0894	22.7798	31.2850
	Swell 5	4.0673	3.7116	22.2078
Bus 7	Sag 7	4.0819	36.36	24.3875
	Swell 7	4.0716	3.3508	35.94

Artificial Neural Network used for classification:

One of the most critical difficulties in constructing the artificial neural network (ANN) is the choice of the number of hidden layers and the number of neurons for each layer. Using too few neurons in the hidden layer may prevent the training process to coverage, while using too many neurons would produce long training time. Many hidden layer neurons may result in divergence. The following graph 1 and 2 shows best training performance graph and training state graph of Artificial Neural Network (ANN). ANN 100% accuracy result value:

The following graph 1 and 2 shows best training performance graph and training state graph of Artificial Neural Network (ANN).

Events	Confusion Matrix		
Voltage Sag	4 22.2%	0 0.0%	100% 0%
Voltage Swell	0 0.0%	14 77.8%	100% 0%
Overall output	100% 0%	100% 0%	100% 0%
	Target Class		



Fig. 11 Best Training Performance graph

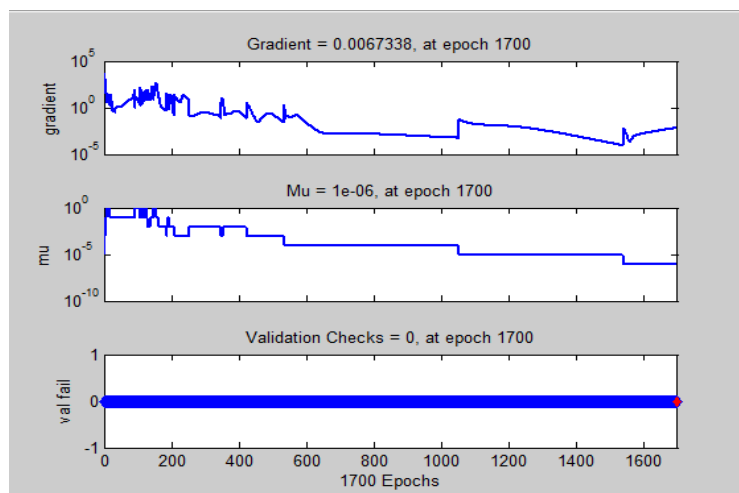

Fig. 12 Training State Graph

VIII. CONCLUSION

This paper presents a method to detect and classify Power quality disturbances. The disturbances classified from IEEE 14-Bus system are Voltage sag and Voltage swell. These Power quality disturbances are detected, classified accurately and further appropriate action can be taken to mitigate it which improves the performance of the system. ANN which is used as classifier gives 100 % accuracy for classification.

REFERENCES

- [1] Nantian Huang, Dianguo Xu, Xiaosheng Liu, Lin Lin, "power quality disturbances based on S-transform and probabilistic neural network", <http://dx.doi.org/10.2016/j.neucom.2011.06.041>.
- [2] A. Rodriguez, J. A. Aguado, F. Martin, J. J. Lopez, F. Munoz and J. E .Ruiz' "Rule-based classification of power quality disturbances using S-transform" Electric Power System Research 86 (2012) 113-121.

-
- [3] Suriya Kaewarsa, Kitti Attakitmongcol, and Thanatchai Kulworawanichpong, “Recognition of power quality events by using multiwavelet-based neural networks”, *Electrical Power and Energy Systems* 30 (2008) 254-260.
 - [4] C. N. bhende, S. Mishra, and B. k. panigrahi, “Detection and classification of power quality disturbances using s-transform and modular neural network”, *Electric Power system research* 78 (2008) 122-128.
 - [5] S. Mishra, C. N. Bhende, and B. K. Panigrahi, Senior Member, IEEE, “Detection and Classification of Power Quality Disturbances Using S-transform and Probabilistic Neural Network”, *IEEE Trans. Power Delivery*, vol. 23, pp 280-287, Jan. 2008.
 - [6] Srividya T, Mr. A. Muni Sankar and Dr. T. Devaraju “Identifying, Classifying Power Quality Disturbances Using Short Time Fourier Transform & S-Transform” *Weekly Science*, pp.2321-7871 Vol-1, Issue-1 ,July 2013.
 - [7] Zwe-Lee Gaing, Member, and IEEE, “Wavelet-Based Neural Network for Power Disturbance Recognition and Classification”, *IEEE Trans. On Power Delivery*, Vol. 19.No. 4, October 2004.
 - [8] W. C. Lee, Member, IEEE, and P. k. Dash, Senior Member, IEEE,” S-Transform-Based Intelligent System for Classification of Power Quality Disturbance Signals”, *IEEE Transaction On Industrial Electronics*, Vol. 50, No. 4, August 2003.
 - [9] Masoud Karimi, Hossein Mokhtari, and M. Reza Iravani, “Wavelet Based On-Line Disturbance Detection for Power Quality Applications”, *IEEE Trans. Power Delivery*, vol.15, no. 4, October 2000.
 - [10] Barry W Kennedy, “Power Quality Primer” [McGraw-Hill, 2000].