

## Survey on IOT & Arduino Based Patient Health Monitoring System

Mr Nitin Halkara, Asst Professor, SIET Sikar  
Amita Pareek, MTech Scholar, SIET Sikar,  
Mr P Lata , Asst Professor, SIT Sikar

**ABSTRACT:** The increased use of Mobile Technologies and Smart Devices in the area of health has caused great impact on the world. Health experts are increasingly taking advantage of the benefits these technologies bring, thus generating a significant improvement in health care in clinical settings and out of them. Likewise, countless ordinary users are being served from the advantages of the M-Health (Mobile Health) applications and E- Health (health care supported by ICT) to improve, help and assist their health. The aim of this paper is to develop an architecture based on an ontology capable of monitoring the health and workout routine recommendations to patients with chronic diseases.

**Keywords:** *Internet of Things, Ontology, E-Health, Context Awareness*

\*\*\*\*\*

### I. INTRODUCTION

A recent healthcare system should provide better healthcare services to people at any time anywhere in an affordable and patient friendly manner. Currently, the healthcare system is going to change from a traditional approach to a modernized patient centered approach. In the traditional way the doctors play the major role. For necessary diagnosis and advising they need to visit the patients. There are two basic problems related to this approach. Firstly, the healthcare professionals must be at place of the patient all the time and second, the patient remains admitted in the hospital, wired to bedside biomedical instruments, for a long period of time. In order to solve these two problems the patient oriented approach has been received. In this theme, the patients are aware with knowledge and information to play a more active role in disease diagnosis, and prevention. The important element of this second approach is a reliable and readily available patient monitoring system (PMS). Health is one of the global challenges for humanity. According to the constitutions of World Health Organization (WHO) the highest attainable standard of health is a fundamental right for an individual. Healthy persons can secure their lifetime income and hence to increase in gross domestic product and in tax revenues. Healthy persons can also reduce pressure on the already overwhelmed hospitals, clinics, and medical professionals and reduce workload on the public safety charities, networks, and governmental or non-governmental centers. To keep people effective and healthy, a readily accessible modern healthcare system is a prerequisite.

### II. INTERNET OF THINGS

Internet of things is defined as Things having identities and virtual personalities operating in smart spaces using intelligent interfaces to connect and communicate within social, environmental, and user contexts. It can be considered the Future of Internet [5], where every object is connected to other objects. Every object is given a unique identity in the network. This allows remote access of devices through the network, anytime and at any location. IoT enabled objects communicate with each other, access information over the Internet, and interact with users creating smart and at any location. IoT enabled objects communicate with each other, access information over the Internet, and interact with users creating smart, pervasive and always connected environments. IoT also enables machine to machine (M2M) communication which allows machines being controlled by the Internet and by other machines. This can revolutionize the way technology is used, as machine takes control of machines overcoming the constraints that people face while communicating with digital systems. Machines can monitor sensors all over the world to generate vast quantity of valuable information that would take a human years to achieve. IoT makes the concept of pervasive computing and ubiquitous computing a reality by allowing objects of our everyday life like cars, roadways, pacemakers, pillshaped cameras in our digestive tracks, billboards that adjust to passersby, refrigerators and even cattle's equipped with sensors to communicate with humans and assisting them in every step. The application of IoT in health-care system is highlighted in the following

section.

### III. LITERATURE REVIEW

**Jorge Gomez:** developed a personal health diagnosis based on the symptoms of the patient. A huge amount of collected data is used to analyse the disease and risk of the patients. Franca discussed that the innovations of the new generation systems are the development of continuous monitoring features for the patient and the improvement of workflows and productivity of medical personal. He also emphasized the various wireless technologies and the advantages of using those technologies

SnehaN.Malokar 1, Samadhan D. Mali2:developed a wearable sensor system to monitor the movements of the patients. The system was calibrated to a threshold level less than 5% with the aim of minimizing the error rate of the captured data proposed a detection system to monitor the movements of patients which recognizes a fall and automatically sends a request for help to the caretakers.

**Giovanni Baldus :** developed an approach to maintain health care data of a patient collected in different geographic locations. The data is available to doctors, hospitals, laboratories etc., to check the medical history of the

of the software for healthcare and proposed an architecture for healthcare and IoT. He has taken the parameters like ECG, blood oxygen, respiration, temperature etc.,

**ArunaDevi.S et al.:**With the increasing health related problems and lack of proper solution in healthcare to monitor the patients in the absence of doctor, the patients face serious problems and lost life in critical conditions, Hence to overcome the absence doctor, the patients face serious problems and lost life in critical conditions, and evaluate the status of each patient by the doctor even in their absence in hospital or near the patient

patients. intelligent systems, which detect the disinfected articles and alerts the medical staff to wash hands after the contact with the disinfectant articles.

Pioggia, IoT techniques can be used to promote healthcare in a better way. The health related information could be interacted with doctors who are in emergency. Even in the absence of the doctor near the patient or in the interacted with doctors who are in emergency. Even in the absence of the doctor near the patient or in the hospital, the doctor can know the patients' status so that the doctor's advice is given in critical cases. Brian Blake commented that the human users could be alerted proactively based on their fitness and historical medical or genetics history .

Franca Delmastro :Data sensed and transmitted through the wireless devices are received in the local system that needs to support accessing of data in heterogeneous formats, can be useful in building real time applications and to be updated in the mobile application of the doctor as well as the user (patients or caregiver). Boyiet. al. presented IoT based system for providing support to emergency medical services system for providing support to emergency medical services by demonstrating how IoT data can be collected and integrated for interoperability. Long et. al. discussed the necessary and requirements details

### IV. COMPARATIVE STUDY

RESEARCH PAPER	TECHNOLOGY	DESCRIPTION	LIMITATIONS
Patient Monitoring System	Wifi, 3G, GPRS	System proposed to give	To get the information about

Based on Internet of Things		proper and efficient medical services by collecting and connecting data through health status monitors.	human health in real time via IoT		Design of Iot Based Smart Health Monitoring and Alert System	Body sensor	The proposed model standardize the medical data,	IOT include embedded technology which allows them to exchange information, with
Patient Monitoring System Based on Internet of Things using	BSN  Technology	Model proposed to interpret  and acquire IOT data emergency data handling and	contains huge amount of smart  object and smart devices connected to the internet for communicati	wearable device.			access and  store data store  data, access and store in unified formal.	each other or the Internet
Rasperry	3G/ CDMA/ GPRS	data sharing  across hospitals.	ng with each other.		Personal Health System architecture for stress monitoring and support to clinical decisions	GSM/GPRS  S/ GPS	Proposed model provide heart  rate, temperature, location of the patient at any given instant.	user interface html webpage will automatically refresh for  every 15  seconds
					Pervasive communication	Zigbee, WiFi, 3G, GPRS,	Proposed model gives the information	The system is designed for long

ications in health care	Bluetooth	about SPO2, GSR-sweating ECG, EMG.	term storage of patient's biomedical information as well assisting health professionals with diagnostic information.
Smart Human	Wifi, Buletooth	Proposed system gives	Maintaining a database
Health Monitoring System by using iot		the platform for fall detection.	server is a must so that there is even track of previous medical record of the patient providing a better and improved examining.

of this system helps patients to trust it. The objective of developing monitoring systems is to reduce health care costs by reducing physician office visits, hospitalizations, and diagnostic testing procedure. Many further improvements can be made in our system to make it better and easily adaptable such as adding more advanced sensors. Because of wireless data transmission over internet, health related data will be send to doctor's personal computer or on his mobile. So, need to go hospital every time and sending message to the doctor gets immediate remedy related to the health condition.

**V. PROPOSED WORK**

The system can be extended by adding more features like location access, linking the ambulance services, leading doctor's list and their specialist , hospitals and their special facilities etc., Doctors can create awareness about diseases and their symptoms through the mobile application. From the evaluation and the result obtained from analysis the system is better for patients and the doctor to improve their patients' medical evaluation.

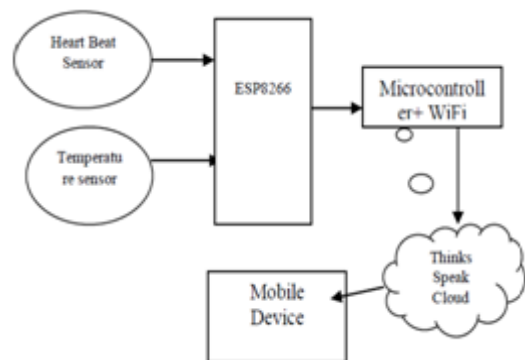

**Figure 1.** Proposed framework architecture

**VI. CONCLUSION**

As health care services are important part of our society, automating these services lessen the burden on humans and eases the measuring process. Also the transparency

The diagram shown above (figure 1) describes the architecture of our proposed framework with the use of Esp8266 and with the description of what happens when attacks are made.

As health care services are important part of our society, automating these services lessen the burden on humans and eases the measuring process. Also the

transparency of this system helps patients to trust it. The objective of developing monitoring systems is to reduce health care costs by reducing physician office visits, hospitalizations, and diagnostic testing procedure. Many further improvements can be made in our system to make it better and easily adaptable such as adding more advanced sensors. Because of wireless data transmission over internet, health related data will be sent to doctor's personal computer or on his mobile. So, need to go hospital every time and sending message to the doctor gets immediate remedy related to the health condition.

## VII. REFERENCES

- [1]. Jorge Gómez, "Patient Monitoring System Based on Internet of Things: A survey", *Computer Networks*, Vol.54, pp. 2787-2805, 2016.
- [2]. Sneha N. Malokar 1, Samadhan D. Mali2, "Patient Monitoring System Based on Internet of Things using RasperryPi: Key features, application and open issues", *Computer Communication*, Vol.54, pp., 2016.
- [3]. GennarTartarisco, "Patient Health Monitoring System using IoT devices <https://www.elprocus.com/wp-content/uploads/2017/07/heartbeat-sensor.jpg>
- [4]. Giovanni Baldus, "Design of Iot Based Smart Health Monitoring and Alert System" 2016 Center for TeleInFrastructure, Aalborg University, Denmark, P.P
- [5]. Pioggia, "Personal Health System architecture for stress monitoring and support to clinical decisions", *Computer Communications* Vol.35, pp.1296-1305, 2017.
- [6]. Franca Delmastro, "Pervasive communications in healthcare", *Computer Communications* Vol.35, pp.1284-1295, 2017.
- [7]. ArunaDevi.S et al. "SMART HUMAN HEALTH MONITORING SYSTEM BY USING IoT/International Journal of Computer Science & Engineering Technology (IJCSSET) ISSN, 2017